



***MOTOR
TRANSPORT
MANUAL***



1992 FORD MUSTANG
ENFORCEMENT VEHICLE
WIRING SCHEMATIC

December 14, 1992

****INDEX****

- 1) MAIN POWER CIRCUIT
- 3) GE RADIO CONTROL HEAD
- 5) SCANNER
- 7) CHP HORN RELAY
- 9) SHOT GUN
- 11) SHOT GUN WARNING CHIME
- 13) WIG WAG UNIT
- 15) TRUNK RELEASE
- 17) MAP LIGHT
- 19) SPOT LIGHTS
- 21) RADAR
- 23) CONTAINMENT BOX FOR VISION ROOF LIGHTS
- 25) VISION ROOF LIGHTS
- 26) CONTAINMENT BOX FOR SIGNAL MASTER DECK LIGHTS
- 28) SIGNAL MASTER DECK LIGHTS
- 29) GROUND CABLE
- 30) EIGHT CONDUCTOR CABLE
- 31) LOCATION OF THE VISION LIGHT BAR PRINTED CIRCUITS
- 32) BAR CONTROLLER (1 OF 2)
- 33) BAR CONTROLLER (2 OF 2)
- 34) LAMP DRIVER
- 35) SIGNAL MASTER
- 36) INTERFACE BOX (1 OF 2)
- 37) INTERFACE BOX (2 OF 2)
- 38) TYPICAL GENERAL ELECTRIC RADIO COMPONENT LAYOUT

December 14, 1992

ALTERNATOR PARTS FOR THE 1992 FORD MUSTANG
CARS THAT HAVE THE VISION ROOF LIGHTS

(ALL PARTS COME OFF A 1992 FORD FULL
SIZE BRONCO WITH A 130 AMPERE ALTERNATOR)

ALTERNATOR	F2UZ-10346-B
ALTERNATOR PULLEY	FOVY-10344-B
LOWER ALTERNATOR BRACKET ASSEMBLY	F2UZ-10A313-A
VOLTAGE REGULATOR	FODZ-10316-A
BRUSH KIT	F1DZ-10347-A
WIRE HARNESS	F2AZ-14305-A
BELT	JK6-884
ALTERNATOR OUT PUT CABLE	5' 6 GAUGE RED

Stores now stock the bulbs and fuses for the new VISION and
SIGNAL MASTER light system

STORES PART NUMBER	UNIT	DESCRIPTION
7-275-50	EACH	30 AMP MAXI FUSE
7-275-55	EACH	40 AMP MAXI FUSE
7-275-60	EACH	60 AMP MAXI FUSE
7-275-65	EACH	80 AMP MAXI FUSE
7-356-80	EACH	50 WATT HALOGEN BULB FOR THE VISION LIGHT BAR
7-356-85	EACH	27 WATT HALOGEN BULB FOR THE SIGNAL MASTER DECK LIGHT AND FOR THE SIGNAL MASTER ON THE BACK OF THE VISION MASTER LIGHT BAR

December 14, 1992

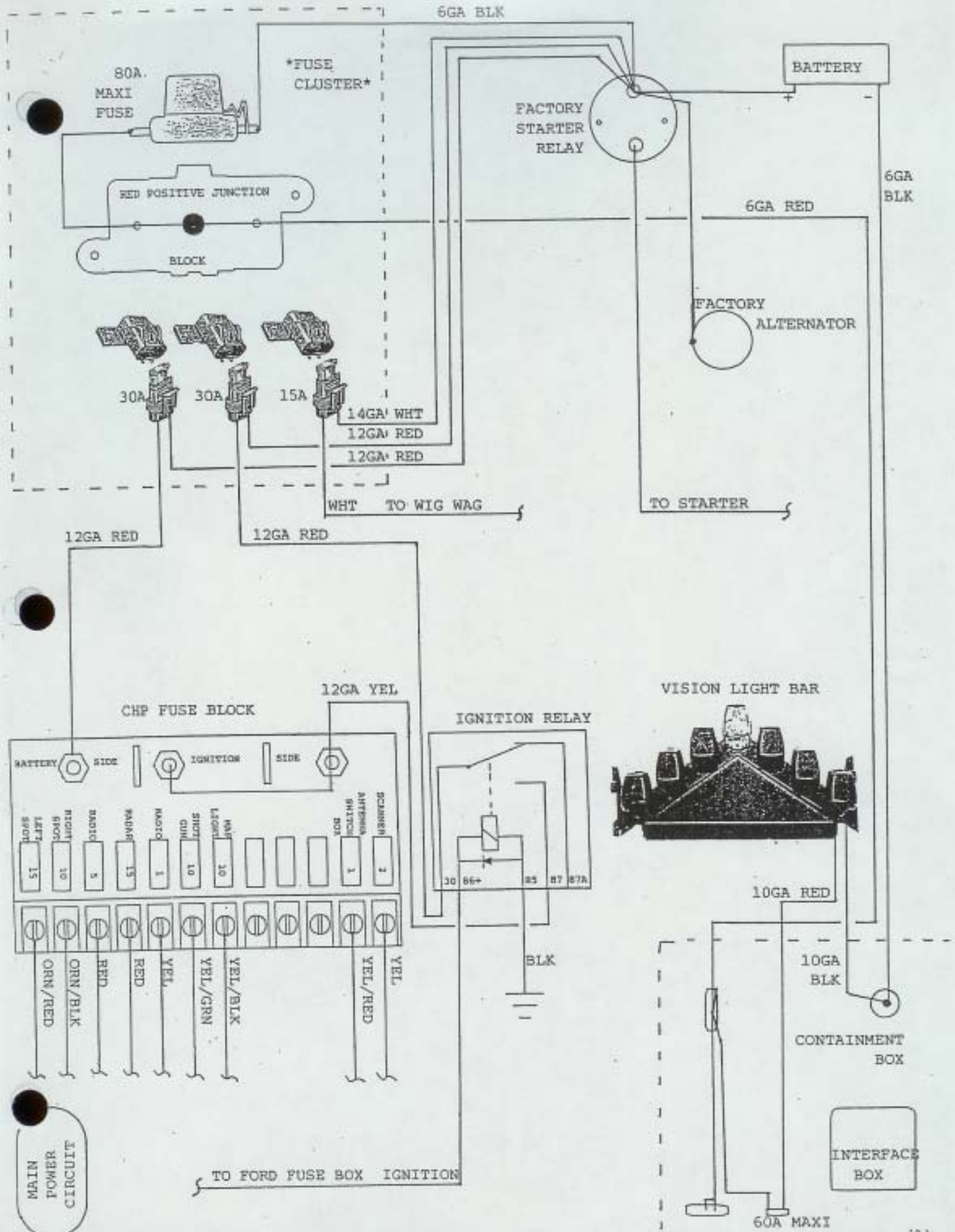

MAIN POWER CIRCUIT

Ford's starter relay	Top center of left front fender behind the plastic cover
CHP fuse cluster	On top of Ford's starter relay's plastic cover on the left front fender
80 amp maxi fuse holder, red positive junction block, and the three inline fuse holders	On top of Ford's starter relay's plastic cover on the left front fender
Wig wag	On top of Ford's starter relay's plastic cover on the left front fender
Alternator	The cars with the Vision roof lights will have a 130 ampere alternator while the deck light car will have a stock 75 ampere alternator
CHP fuse block and CHP ignition relay	Under the steering column
CHP ignition relay's coil feed (terminal 86+)	In ford's fuse box in the ignition cavity under the fuse # 8 (radio)
CHP ignition relay's coil ground wire	Grounded at the bottom of the shot gun support along with a jumper wire to behind the right kick panel for a chassis ground connection
Containment box	In the trunk on the radio board

December 4, 1992

RADIO CONTROL HEAD

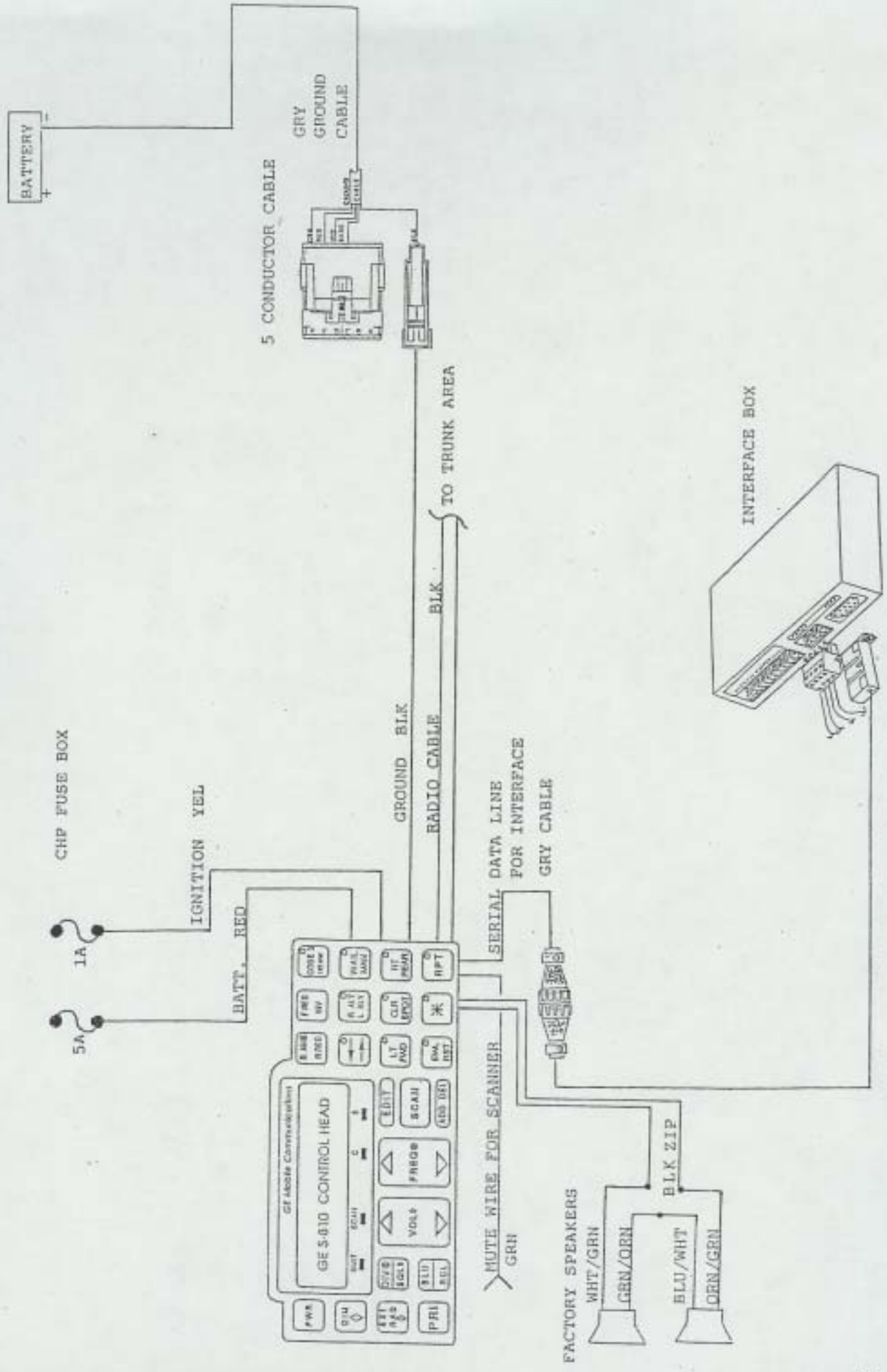

GE CONTROL HEAD

CHP fuse box	Left side of the steering column
Five conductor ground cable	Behind center console
Mute wire connector	Behind center console
Serial data line connector	Behind center console
Radio cable and data line	Routed on the right side of the car
Factory connector for the front speakers	Behind center console
Interface box	In the trunk

December 2, 1992

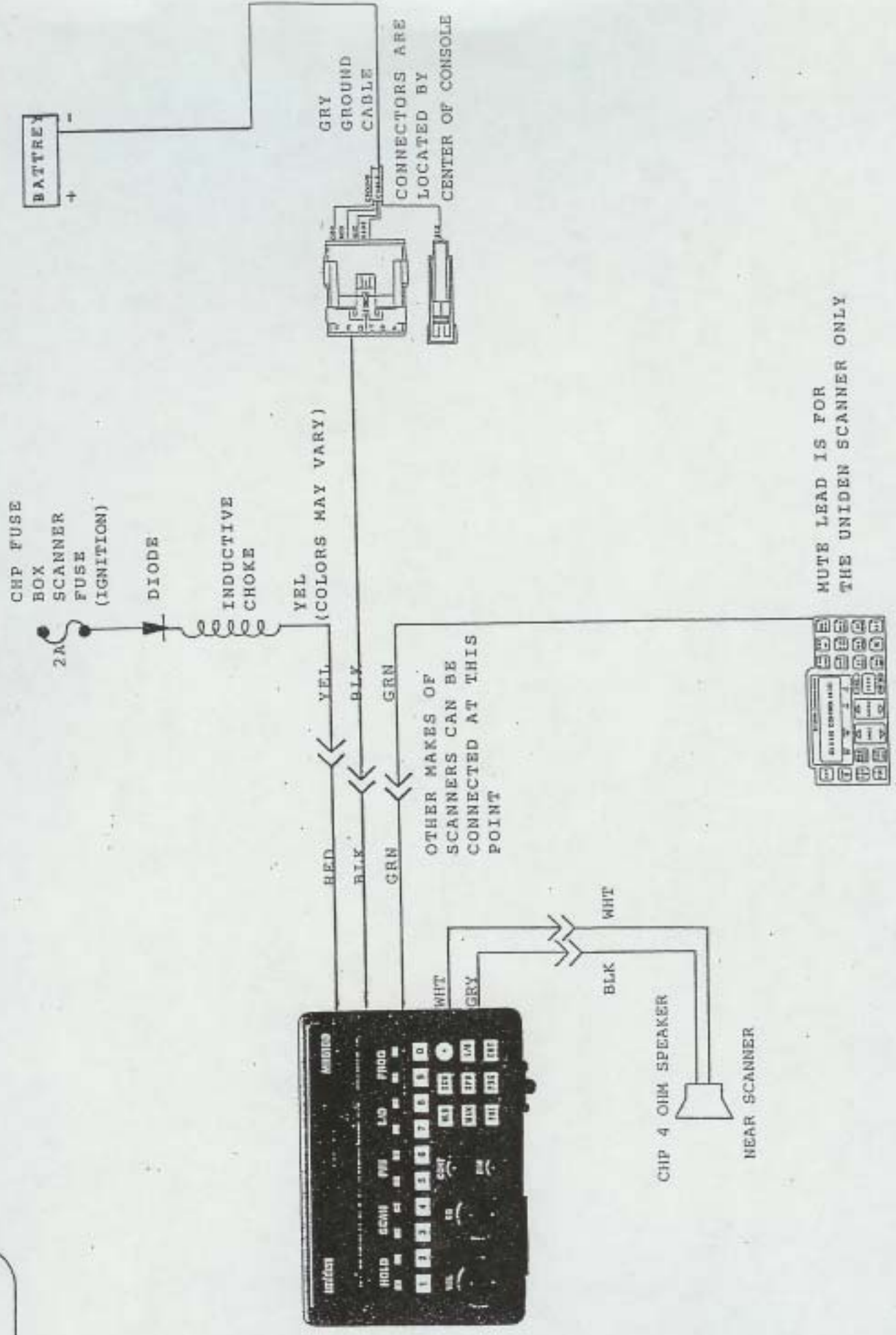

SCANNER

Scanner's "ignition" fuse	CHP fuse block under steering column
Diode and inductive choke	Next to CHP fuse block under steering column
Five conductor ground cable	Under center of dash behind center console
Scanner connections	Right rear of center console
Scanner speaker	On top side of shot gun support

December 2, 1992

CHP
HORN
RELAY

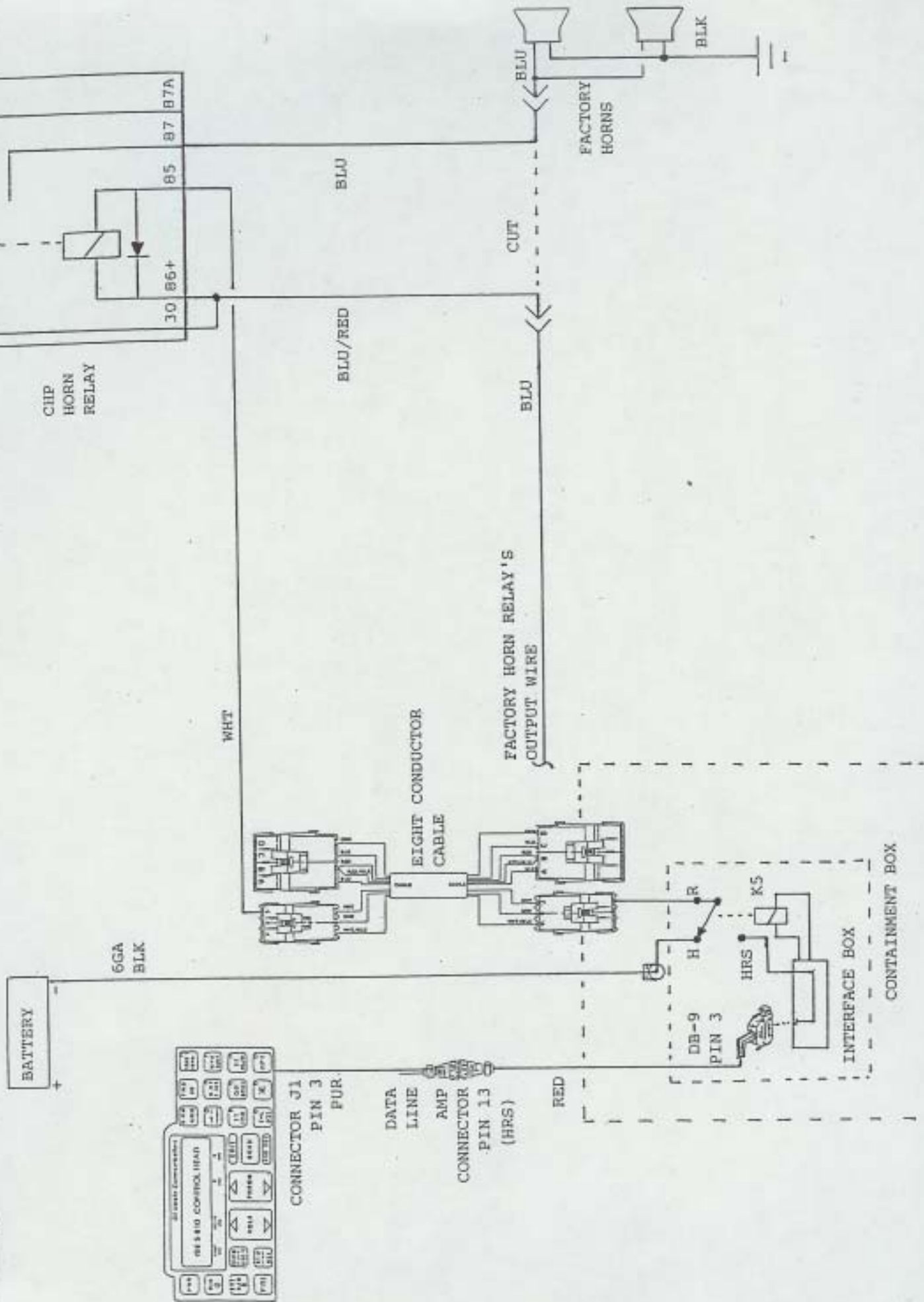

CHP HORN RELAY

Operation: When the CODE-3 button or the second push of the F-RED button are activated, the K-5 relay inside the interface box will switch from the "H" terminal to the "HRS" terminal as requested from the data line. At this point when the horn contacts are activated at the steering wheel, 12 volts will be sent through the CHP horn relay, then through the eight conductor cable, then through the "HRS" terminal of the K-5 relay, then through the interface printed circuit (pc), then ran by hard wire to the GE radio control head through the data line cable. Being high impedance the radio control head will not allow enough current through the CHP horn relay to activate it. But the 12 volts will be enough to tell the control head that the horn button has been pushed and that it can activate the siren

Chp horn relay

By the factory starter solenoid, behind the plastic cover.

Factory horn relay

Center of dash, left of the console, on top of the seat belt chime bracket.

Cut (wire)

By the factory starter solenoid, behind the plastic cover.

Factory horns

Underneath left front fender.

Eight conductor cable

One end of the cable is located behind the center console the other end is at the interface box in the trunk. The cable is routed on the right side of the car.

Data cable

A 9 conductor cable is routed on the right side of the car

Amp connector

Behind the center console

December 9, 1992

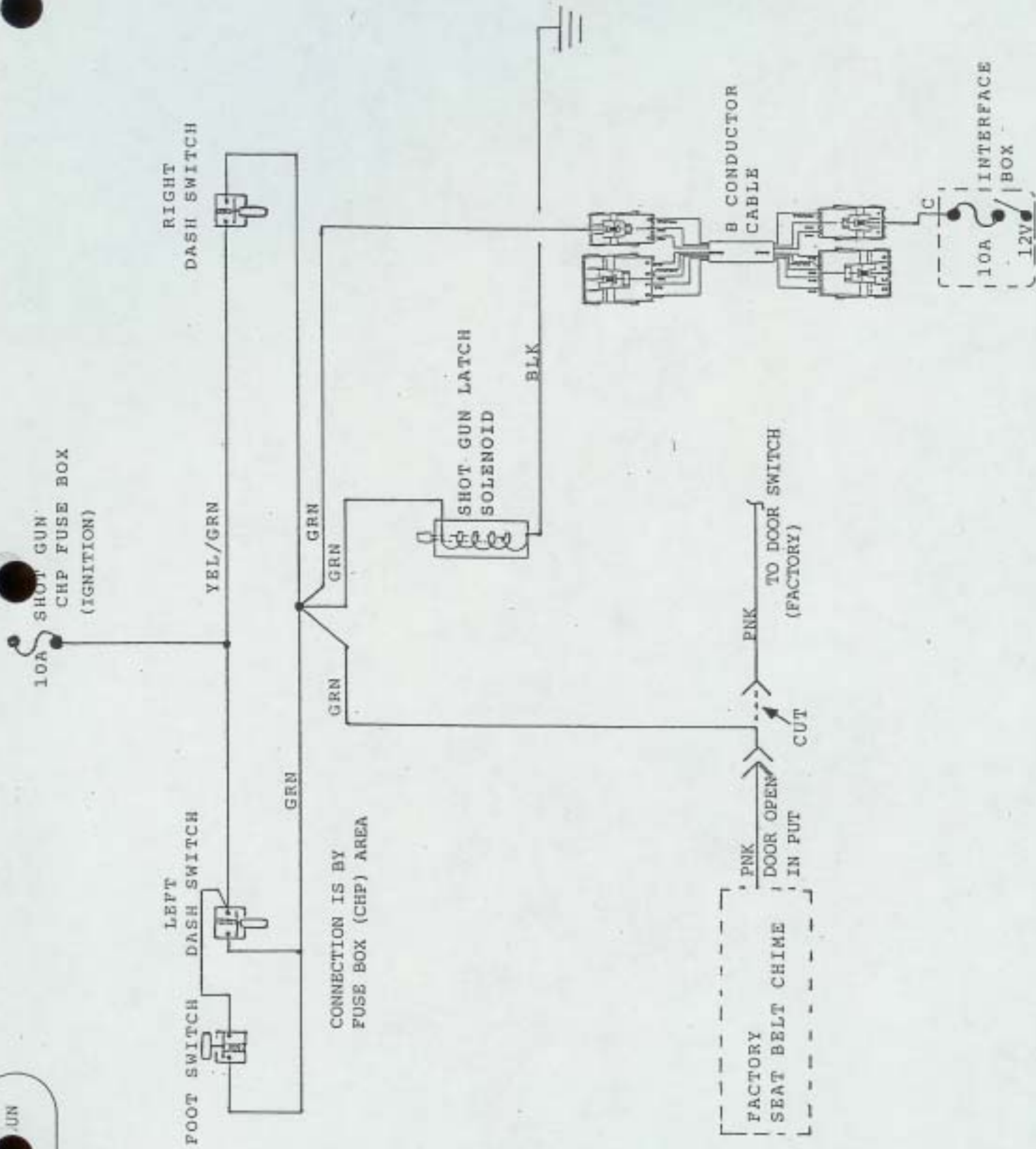

SHOT GUN

Operation: To activate the shot gun from the GE radio control head push the asterisk button and then push the WAIL/MAN button which will then through the data line activate the relay K-3 inside the INTERFACE BOX sending 12 volts for eight seconds to the shot gun latch solenoid (electrolock) and chime.

Shot gun fuse	CHP fuse block under steering column
Foot switch	Drivers floor board
Left dash switch	Under dash next to the left kick panel
Right dash switch	Under dash next to the right side kick panel
Five wire connection	Next to the CHP fuse block
Latch solenoid	On the shot gun bracket
Latch solenoid ground	Behind right kick panel
Factory seat belt chime	Under dash, on left side of console, white in color, bracket held in by two screws
Eight conductor cable	One behind console, the routed on the right side of the car and the other end of the cable is at the interface box in the trunk
Interface box	In the trunk

December 9, 1992

SHOT GUN
CHIME

WARNING CHIME
LOCATED ON THE RIGHT
SIDE OF THE STEERING
COLUMN, WHT IN COLOR
(FACTORY)

FORD'S DASH LIGHT

15A FUSE

FORD'S
FUSE BOX
IGNITION

10A

FORD'S
FUSE BOX
BATTERY

15A

SWITCH,
CLOSED WITH
HEAD
LIGHTS
ON

GRN/YEL

DOOR INPUT
SWITCH CLOSED
WITH DOOR OPEN
(FACTORY)

*CUT

PNW

TO SHOT GUN SOLENIOD
GRN

(FACTORY)
SEAT BELT
DASH LIGHT

DASH LIGHT
OUTPUT BRN/GRN

IGNITION ON
INPUT RED/YEL

DOOR OPEN INPUT PNK

LIGHTS ON INPUT BRN

CLOSED WITH
HEAD LIGHTS OR
RUNNING LIGHTS ON
(FACTORY)

KEY IN IGNITION INPUT
BLK/PNK

CLOSED WHEN
KEY IS IN THE
IGNITION SWITCH
(FACTORY)

GROUND

BLK

DRIVER'S SEAT BELT INPUT BRN/BLU

*CUT AND INSTALL
BUFF CONNECTORS

OPEN WITH
DRIVER'S SEAT
BELT BUCKLED
(FACTORY)

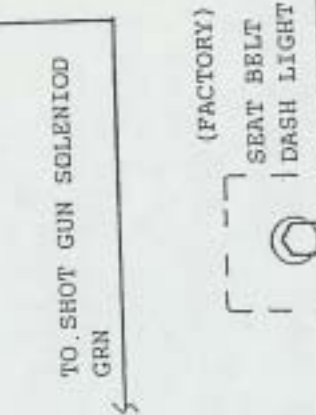
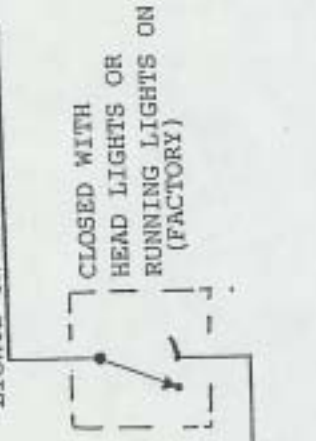
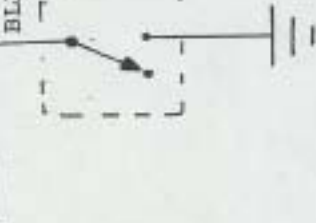
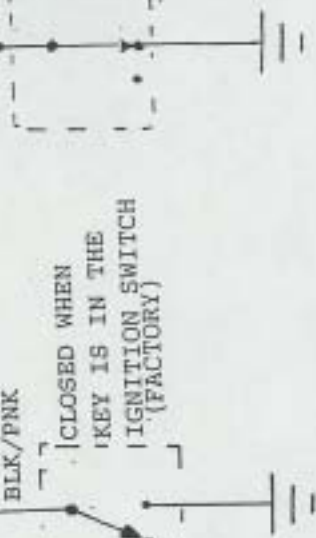
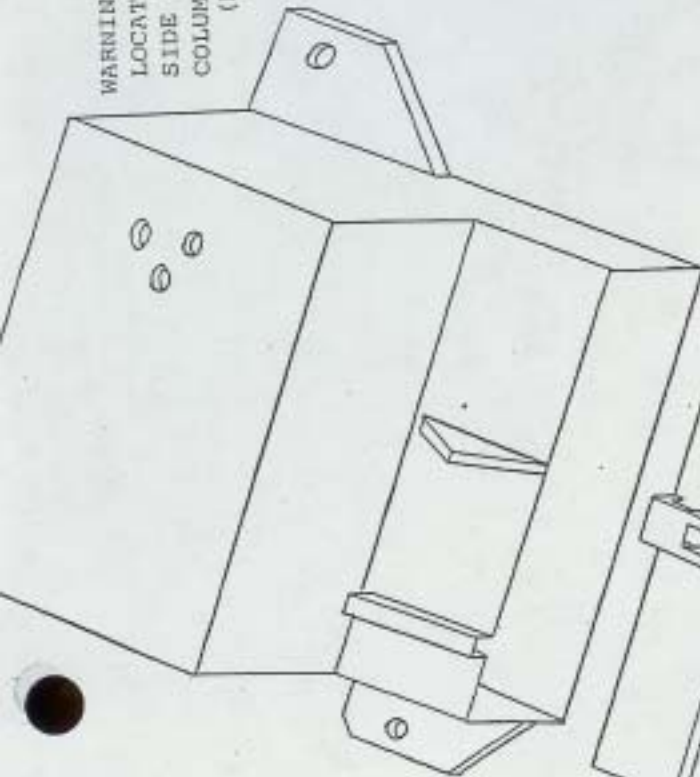

SHOT GUN CHIME

Shot gun chime

Under the center of the dash at the left side of the center console, chime is white in color, and the bracket is held in be two screws

Ford's "battery" fuse

Ford's fuse box left side of dash, fuse number 8

Ford's "ignition" fuse

Ford's fuse box left side of dash, fuse number 18

Ford's "light" fuse

Ford's fuse box left side of dash, fuse number 4

Cut wires

both cut wires are made at the factory seat belt warning chime connector

December 2, 1992

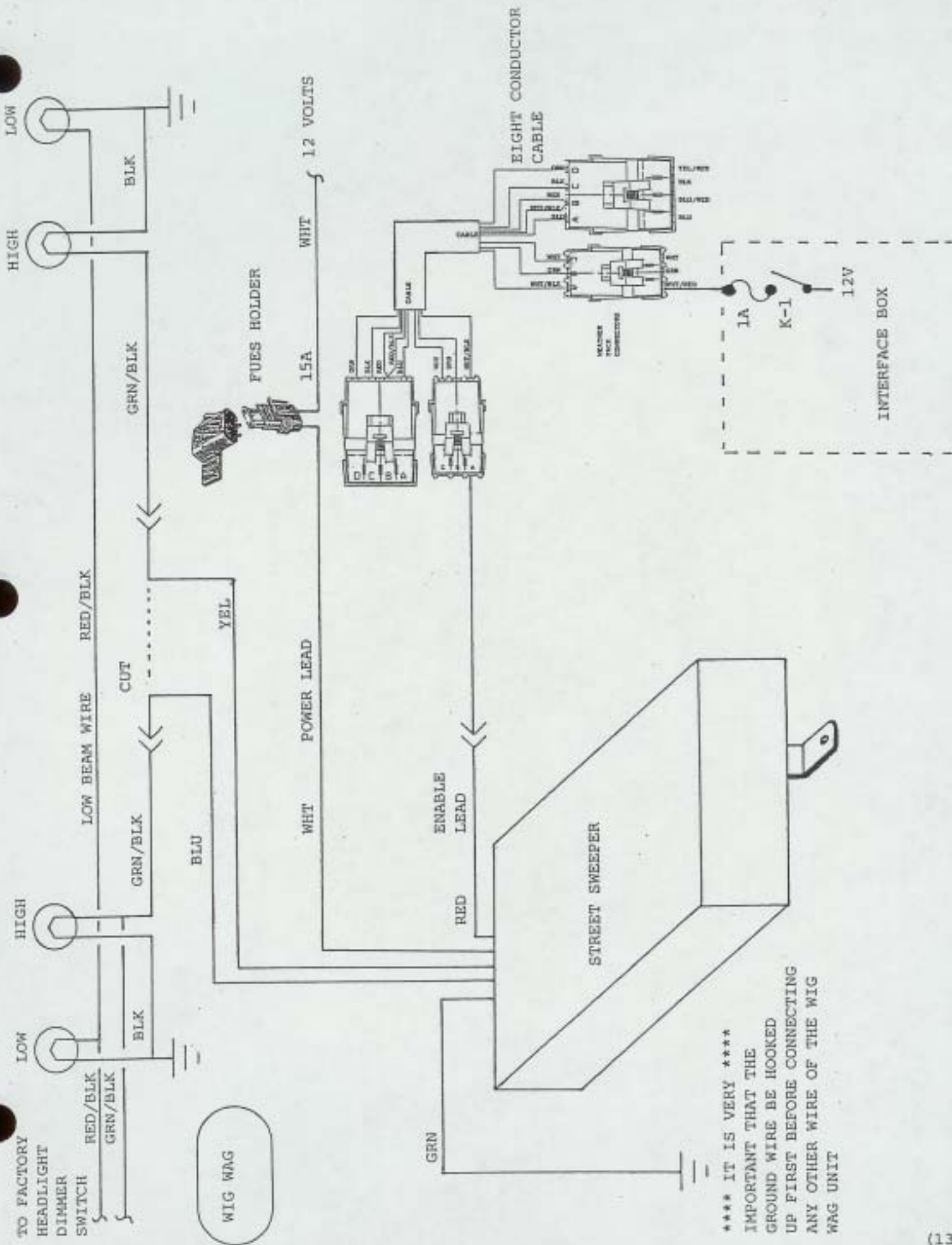

**** IT IS VERY ****
 IMPORTANT THAT THE
 GROUND WIRE BE HOOKED
 UP FIRST BEFORE CONNECTING
 ANY OTHER WIRE OF THE WIG
 WAG UNIT

WIG WAG

Operation: Activating the wig wag through the GE radio control head will apply 12 volts to the red wire of the WIG WAG unit, as long as there is no voltage present at the wig wag's blue wire from the cars dimmer switch the wig wag will alternately send 12 volts out on the blue and yellow wires to the proper head lights. If there is a input of 12 volts on the wig wag's blue wire (indicating high beam request) the wig wag unit will then send out 12 volts on the yellow wire to activate the right side head lamp and at the same time the wig wag will disable the alternating flash operation. The wig wag operates only on the high beam circuit.

Wig wag	By factor starter solenoid on top of the plastic cover
Cut (wire)	Left front radiator support
Fuse holder	By factor starter solenoid on the side of the plastic cover, and the lead wire is attached to the factory starter solenoid
Eight conductor cable	One connector is behind the center console the other on is at the interface box in the trunk, the cable is routed on the right side of the car
Interface box	In the trunk
Wig wag ground	Left front fender

December 9, 1992

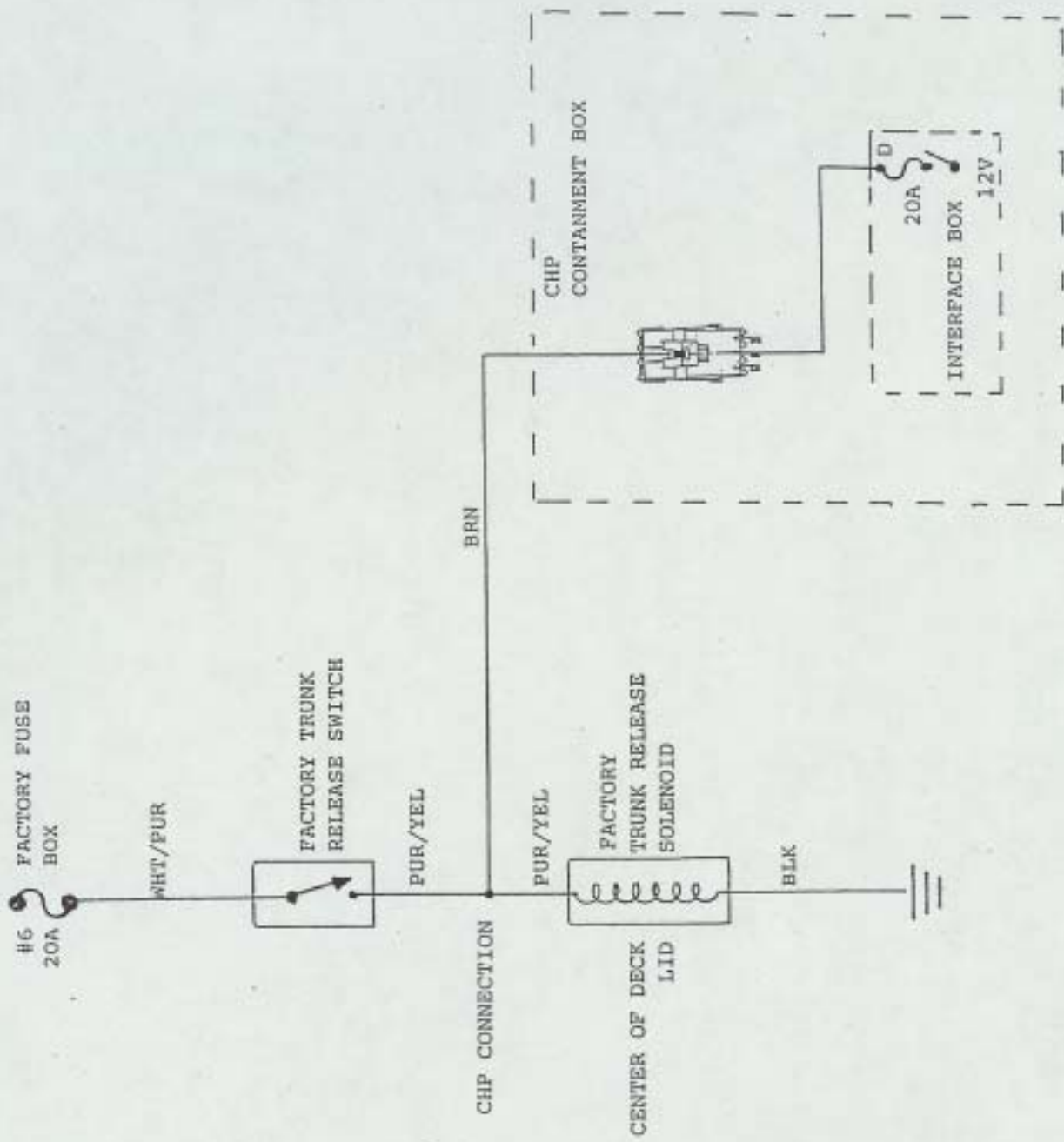

TRUNK RELEASE

Operation: To activate the trunk release from the GE radio control head, push the asterisk button and then push the Lt./FWD button which will then through the data line activate the relay K-4 inside the INTERFACE BOX sending 12 volts to the trunk release solenoid.

Factory fuse	Factory fuse box is in the left side of the dash, fuse number 6
Factory trunk release switch	Right side of the steering column
CHP connection	Left deck lid hinge area
Trunk release solenoid	Center of deck lid
Interface box	In the trunk

December 9, 1992

MAP LIGHT

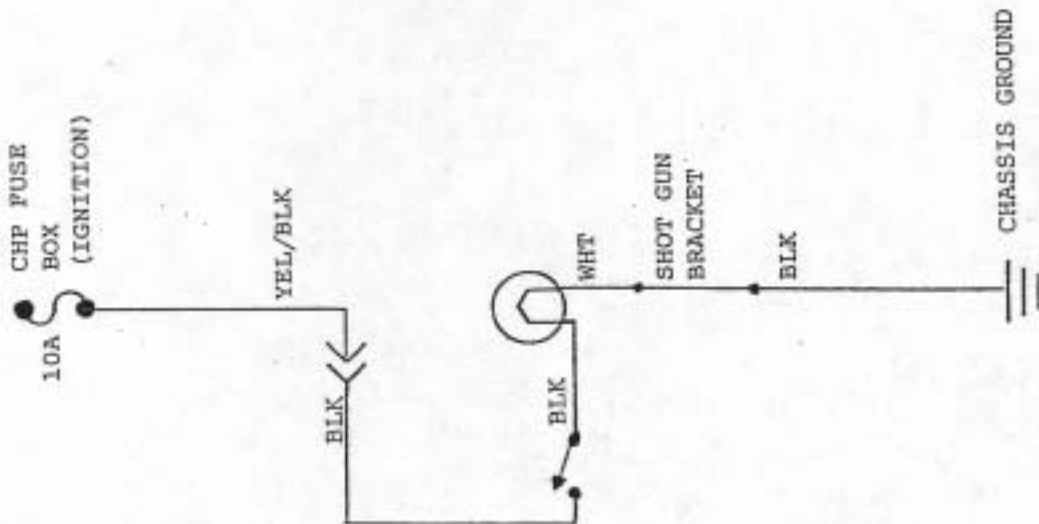

MAP LIGHT

CHP map light

On the shot gun support

CHP fuse box

Under the steering column

Ground

From the base of the shot gun support bracket to the chassis ground behind the right kick panel

December 2, 1992

SPOT LIGHTS

RED LIGHT UNLESS EQUIPPED WITH A CENTER RED MIRROR LIGHT THEN IT IS A CLEAR SPOT LIGHT



ENTER RED MIRROR LIGHT (IF EQUIPPED)

BLU/RED 4 "PIG TAIL" BLK

CHP FUSE BOX

15A LEFT SPOT (BATTERY)

ORN/RED

BLU/RED

CHP FUSE BOX

10A RIGHT SPOT (BATTERY)

ORN/BLK

BLK

SPOT LIGHT HANDLE SWITCH



CLEAR SPOT

IF NOT EQUIPPED WITH A CENTER RED MIRROR LIGHT THE BLU/RED WIRE WILL BE ATTACHED TO THE RED WIRE OF THE SPOT LIGHT HANDLE

8 CONDUCTOR CABLE

CONTAINMENT BOX

BLU/RED

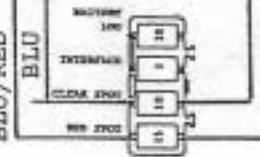

20A CLEAR SPOT LIGHT

30A RED LIGHT

DECK LIGHT INTERFACE BOX

SPOT LIGHTS

Operation: For roof light cars to activate the right side clear spot light from the GE radio control head, push the asterisk button and then push the CLR/SPOT button which will then through the data line activate the relay K-2 inside the INTERFACE BOX sending 12 volts to the right hand spot light.

For the deck light cars you do not need to push the asterisk button to activate the right hand side spot light.

For the front red light push either the CODE-3 button or the F-RED button on the GE radio control head to activate the light.

Left spot light fuse	In CHP fuse block which is under the steering column
Right spot light fuse	In CHP fuse block which is under the steering column
Center red mirror light	Attached to the rear view mirror (if equipped) the lead wire BLU/RED will be ran down the drivers pillar post molding
Left spot light connectors	Above left side kick panel
Right spot light connectors	Above right side kick panel
Eight conductor cable	One connector is behind the center console the other one is at the Interface box in the trunk, the cable is routed on the right side of the car.
Containment box	In side the trunk

December 9, 1992

15A
CHP FUSE BOX
RADAR

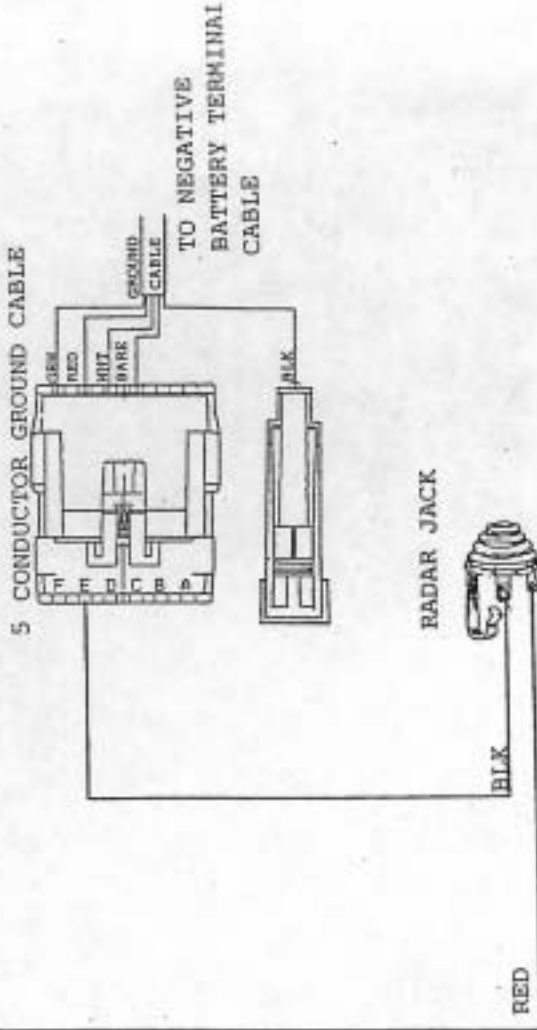

RADAR

Radar fuse

In CHP fuse block under the steering column

Five conductor ground cable

Under the center of the dash behind the center console, and is routed over to the drivers side and through the fire wall to the negative battery cable

Radar jack

On the shot gun support

December 2, 1992

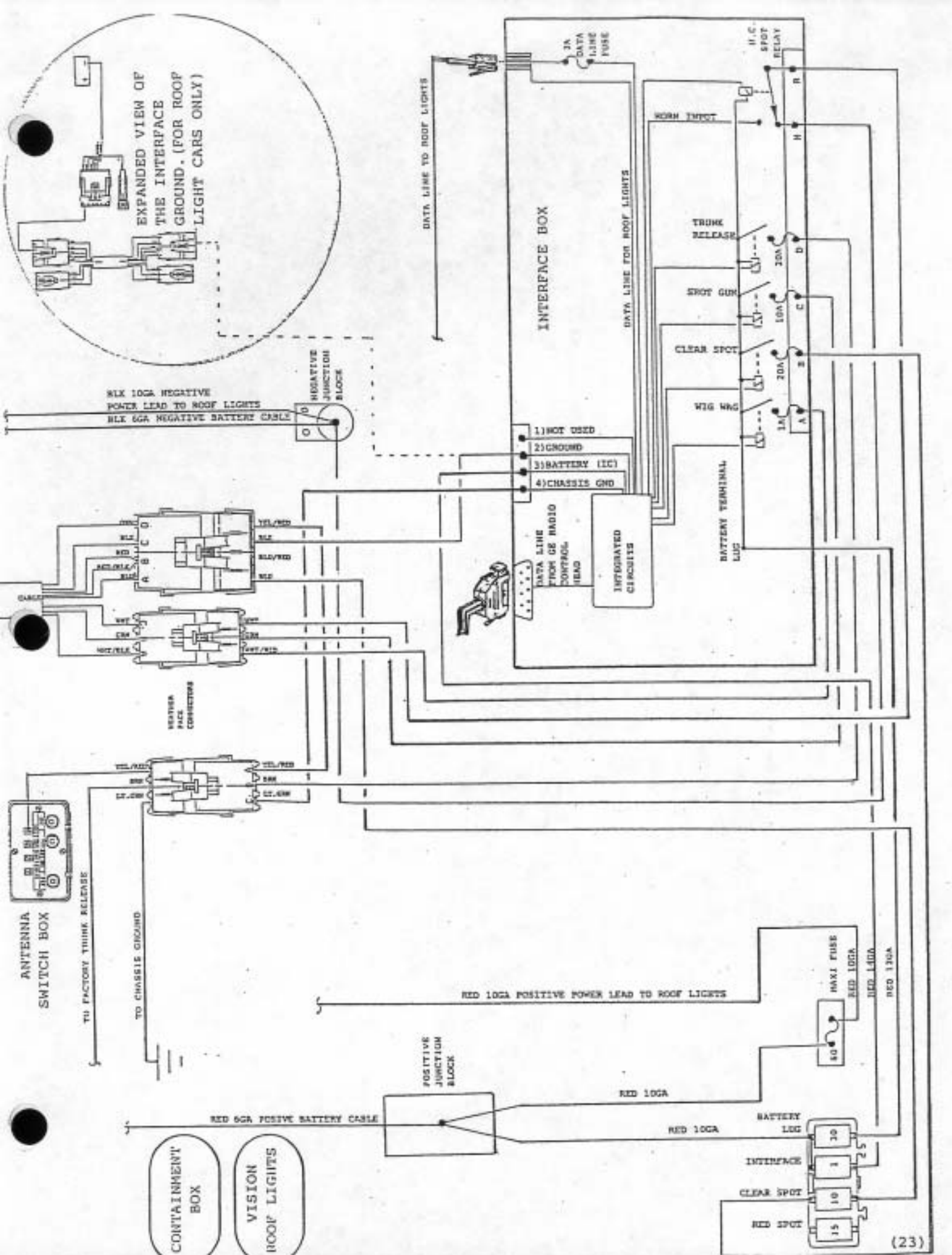

CONTAINMENT BOX FOR THE VISION ROOF LIGHTS

Containment box

In right side of trunk on the radio board

Interface box

Inside containment box

Chassis ground

On the right side hinge area

Roof light power cables and data line

Routed on the right side of the car and along "B" pillar post

Positive junction block, external fuse block, maxi fuse holder weather pack connectors, negative junction block

All are inside the containment box

Expanded view of Interface

The vision Interface ground needs to go directly to the battery ground do not hook it up to the negative junction block at the containment box or the radio negative junction block

December 2, 1992

VISION

ROOF LIGHTS

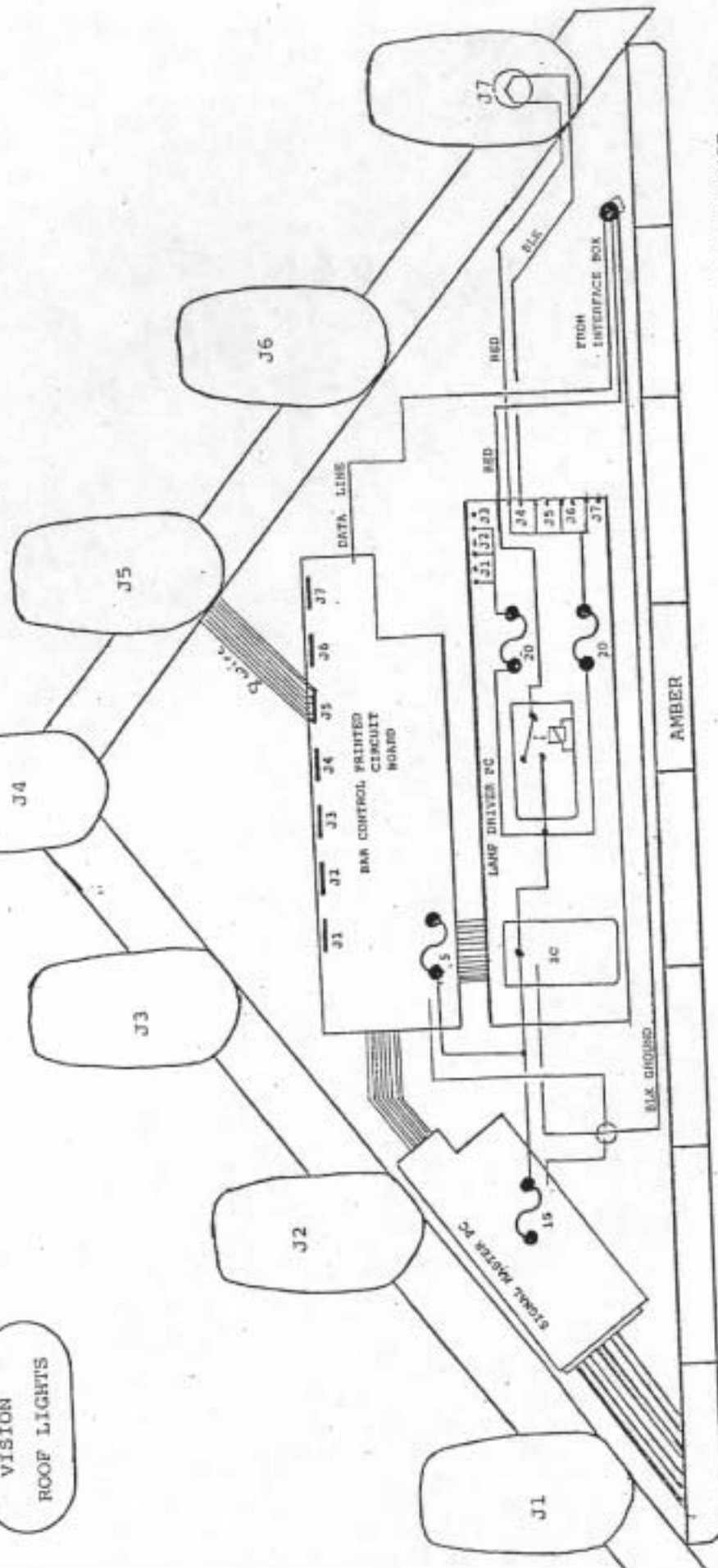

BAR CONTROL - IS A MICROPROCESSOR WHICH PROVIDES THE INTELLIGENCE OF THE LIGHT BAR. IT CONTROLS THE SEQUENCE OF ALL THE LAMPS, THE OPERATION AND SEQUENCE OF THE STEPPER MOTORS, AND PERFORMS A SELF TEST ON ALL THE OUT PUTS ON START UP.

LAMP DRIVER - CONTROLS THE ON/OFF STATUS OF THE LAMPS J1 THROUGH J7. THE LAMPS J1-J7 ARE A OSRAM 64170 A 4 AMP 50 WATT HALOGEN BULB. THE OPERATION OF THE LAMPS ARE OF A CONTROLLED GROUND TYPE (THE LAMPS ARE FED 12 VOLTS AND THEN THE LAMP DRIVER CONTROLS THE GROUND CIRCUIT TO ACTIVATE THE LAMP).

SIGNAL MASTER - CONTROLS THE ON/OFF STATUS OF THE REAR AMBER LAMPS. THEY ARE A GENERAL ELECTRIC GH-22, A 27 WATT HALOGEN BULB. THE OPERATION IS ALSO OF THE CONTROLLED GROUND TYPE.

*****WARNING THE VISION LIGHT BAR CONTAINS ELECTROSTATIC SENSITIVE COMPONENTS*****

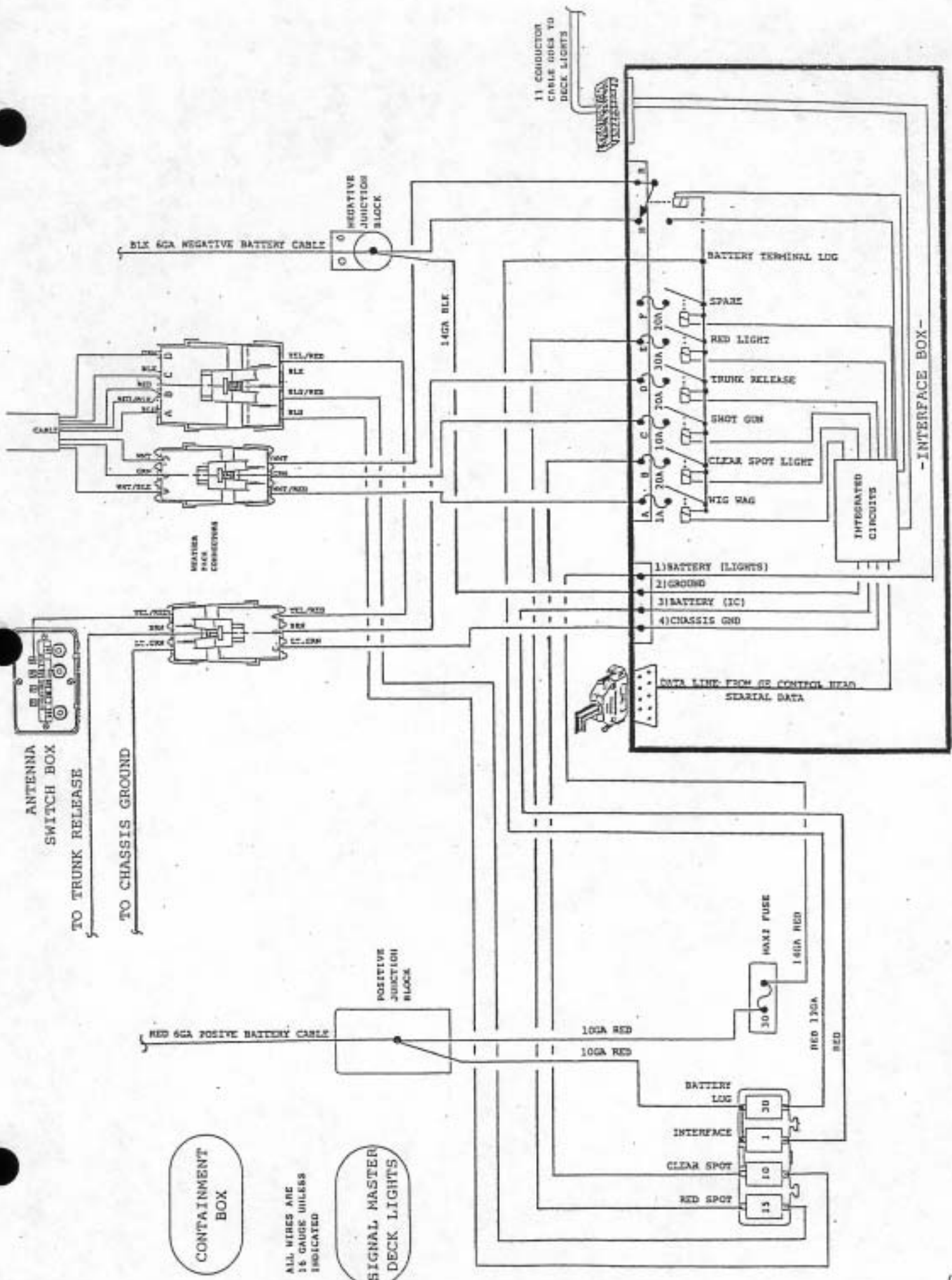

11 CONDUCTOR CABLE GOES TO DECK LIGHTS

BLE 6GA NEGATIVE BATTERY CABLE

NEGATIVE JUNCTION BLOCK

14GA BLE

BATTERY TERMINAL LOG

SPARE

RED LIGHT

TRUNK RELEASE

SHOT GUN

CLEAR SPOT LIGHT

WIG WAG

INTEGRATED CIRCUITS

INTERFACE BOX

1) BATTERY (LIGHTS)

2) GROUND

3) BATTERY (IC)

4) CHASSIS GND

DATA LINE FROM DE CONTROL HEAD SERIAL DATA

ANTENNA SWITCH BOX

TO TRUNK RELEASE

TO CHASSIS GROUND

CONTAINMENT BOX

ALL WIRES ARE 16 GAUGE UNLESS INDICATED

SIGNAL MASTER DECK LIGHTS

MAXI FUSE

14GA RED

RED 13GA

RED

10GA RED

10GA RED

BATTERY LOG

INTERFACE

CLEAR SPOT

RED SPOT

30

30

1

10

15

CONTAINMENT BOX FOR THE "SIGNAL MASTER" DECK LIGHTS

Containment box	In the right side of the trunk on the radio board
Interface box	Inside containment box
Chassis ground	On the right side of the deck lid hinge area
Positive junction block, external fuse block, MAXI fuse holder, weather pack connectors and negative junction block	All are inside the containment box

SIGNAL
MASTER
DECK
LIGHTS

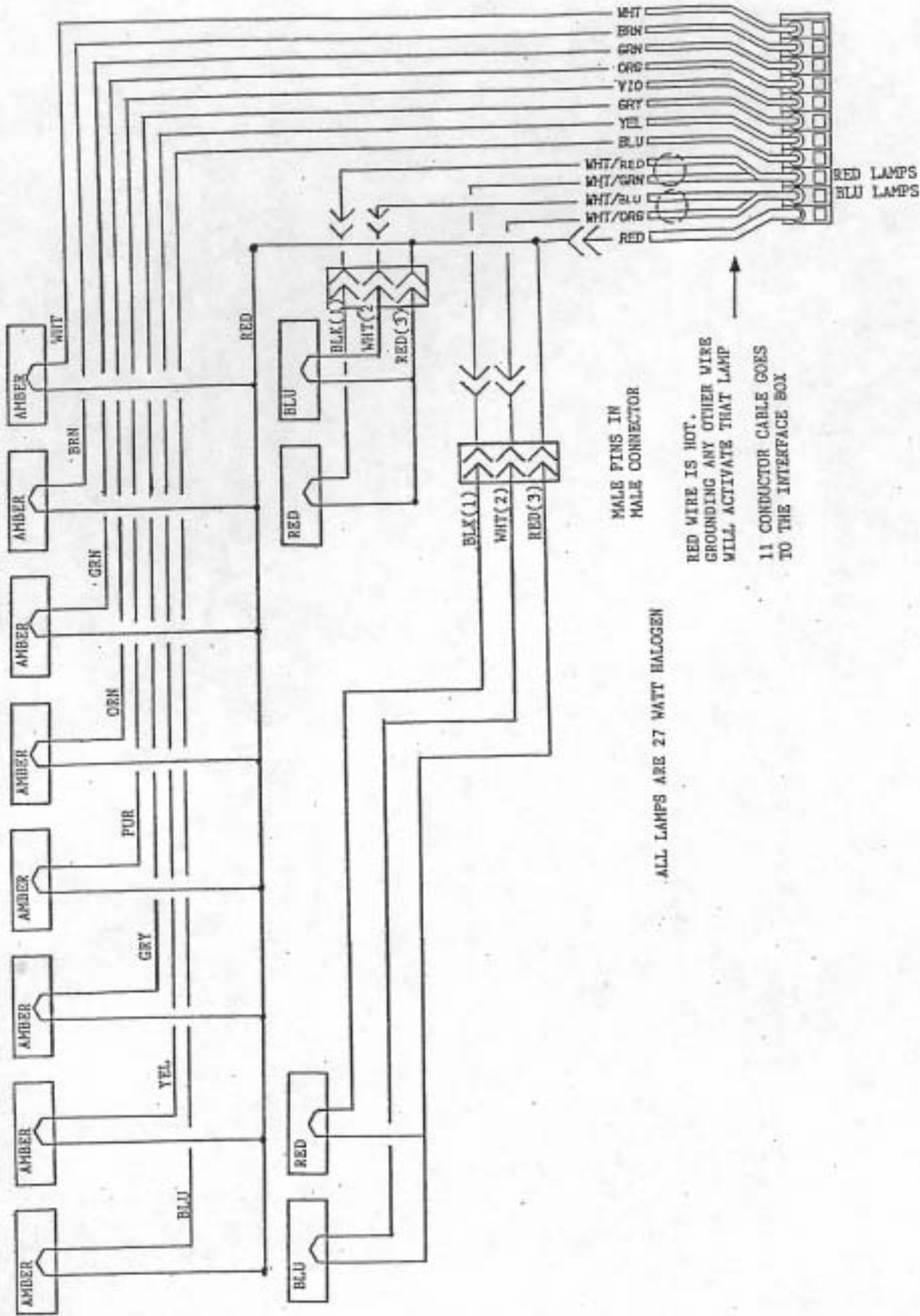

MALE PINS IN
MALE CONNECTOR

ALL LAMPS ARE 27 WATT HALOGEN

RED WIRE IS HOT.
GROUNDING ANY OTHER WIRE
WILL ACTIVATE THAT LAMP
11 CONDUCTOR CABLE GOES
TO THE INTERFACE BOX

GROUND
CABLE

16 GAUGE WIRE

10' LONG 5 CONDUCTOR CABLE

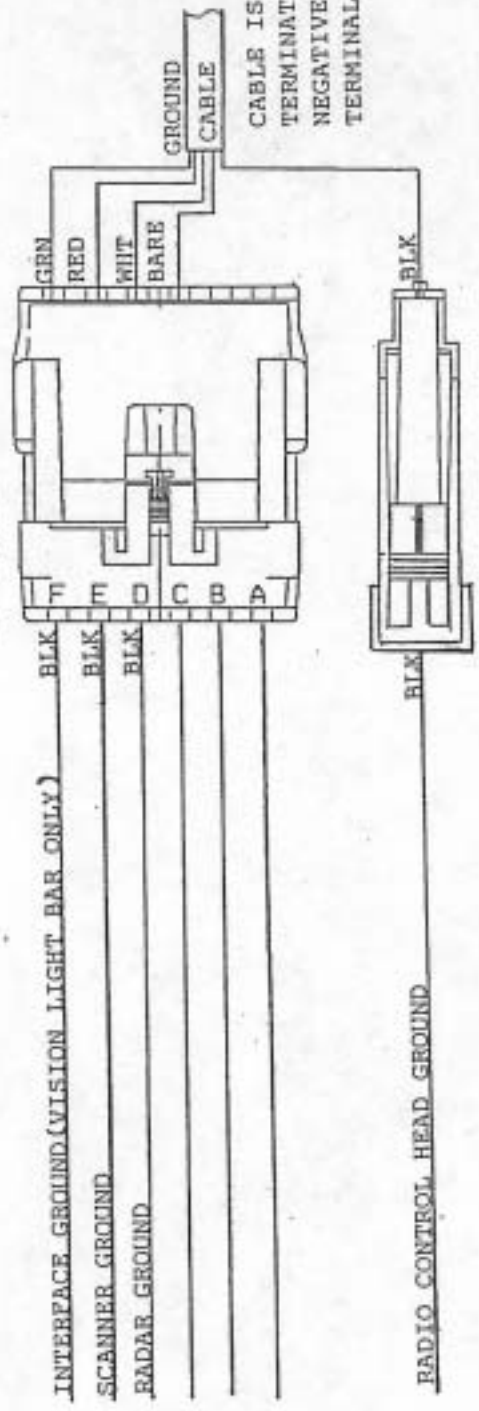

EIGHT
CONDUCTOR
CABLE

PIONEER (PACKARD BRANCH)
WEATHER PACK CONNECTORS ONE END IS
LOCATED BY CHP FUSE BOX THE OTHER END IS
LOCATED AT THE INTERFACE BOX IN TRUNK

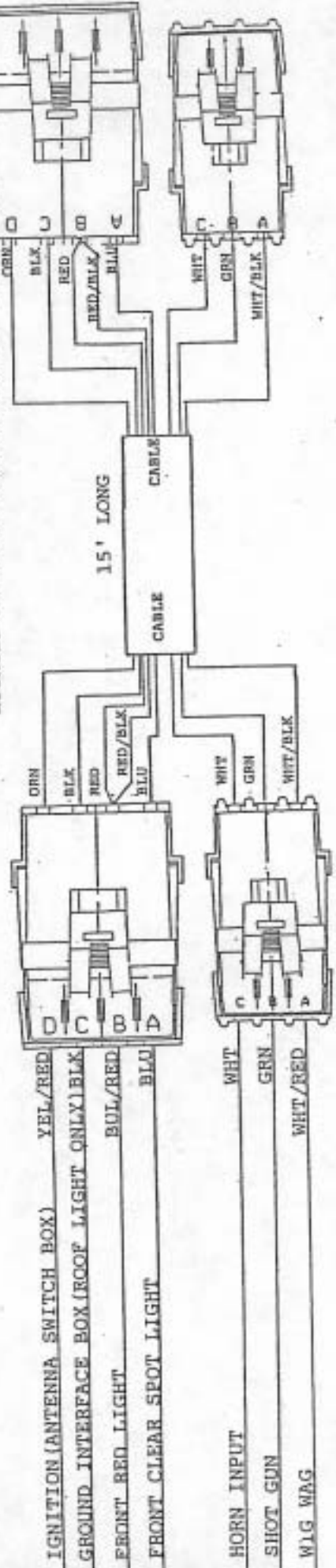

ION
LIGHT BAR
PC BOARDS

BAR CONTROL
CIRCUIT BOARD

LAMP DRIVER
CIRCUIT BOARD

SIGNALMASTER
CIRCUIT BOARD
(OPTIONAL)

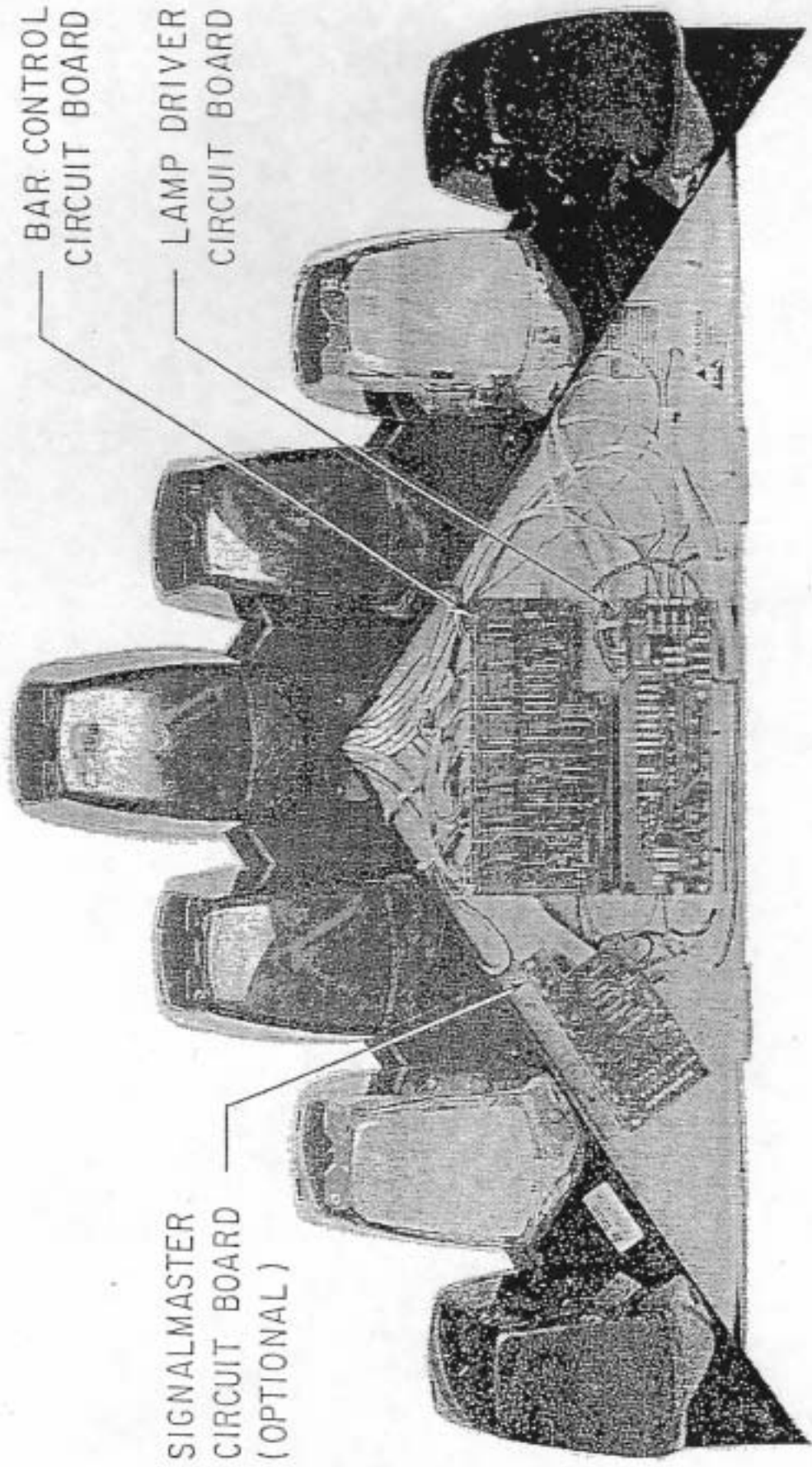

RJ-45
CONNECTOR

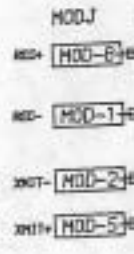

RIBBON
CONNECTOR
TO THE
SIGNAL MASTER
PC BOARD

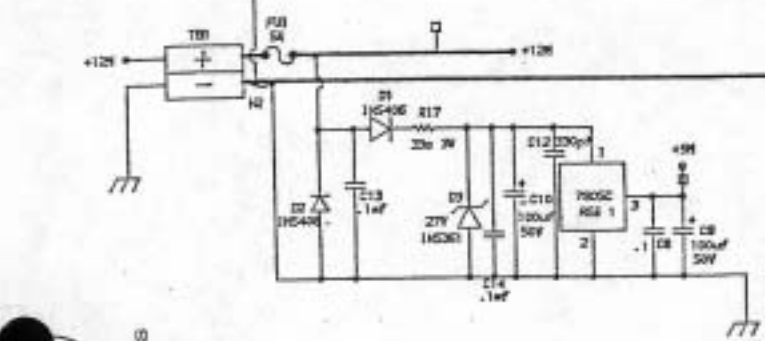
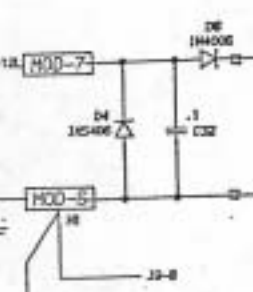
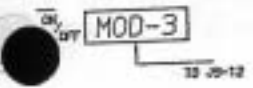
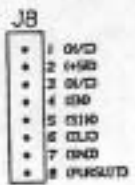

BAR
CONTROLLER
PC BOARD

1 of 2 pages

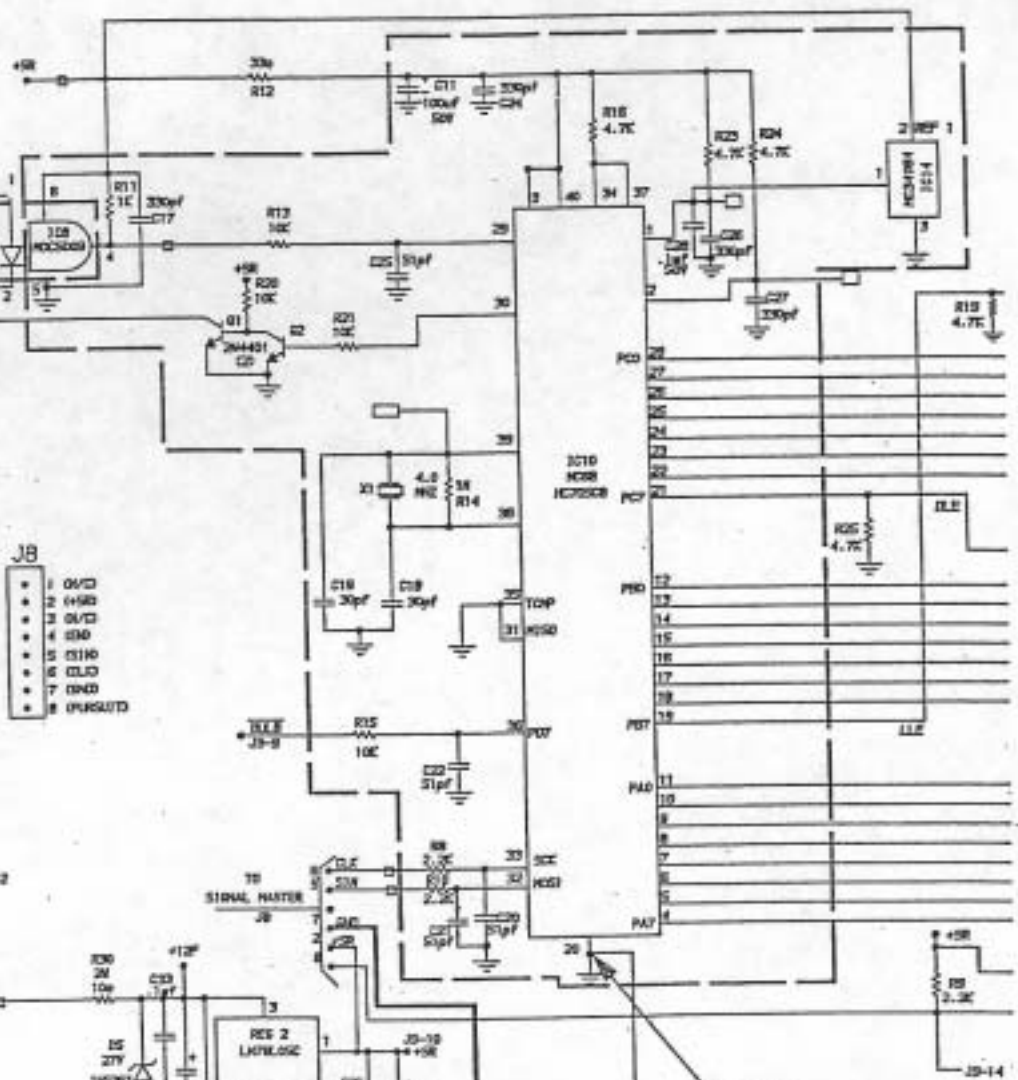

NOTE:
ALL GROUNDS
WITHIN DASHED
BOX TO BE
CONNECTED BY
A STAR GROUND
METHOD FROM
PIN 20 OF IC10

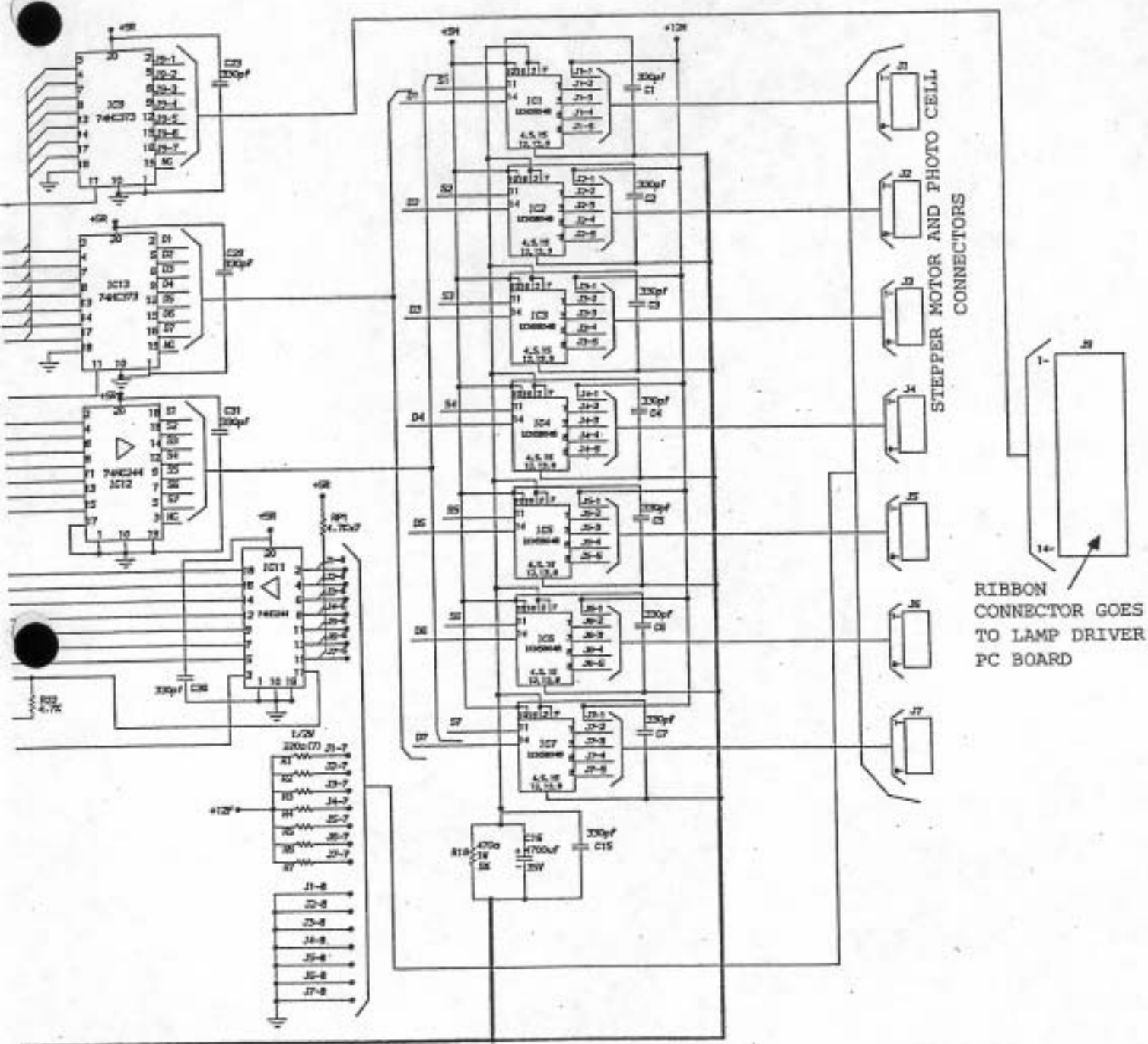

VISION
LAMP DRIVER
PC BOARD

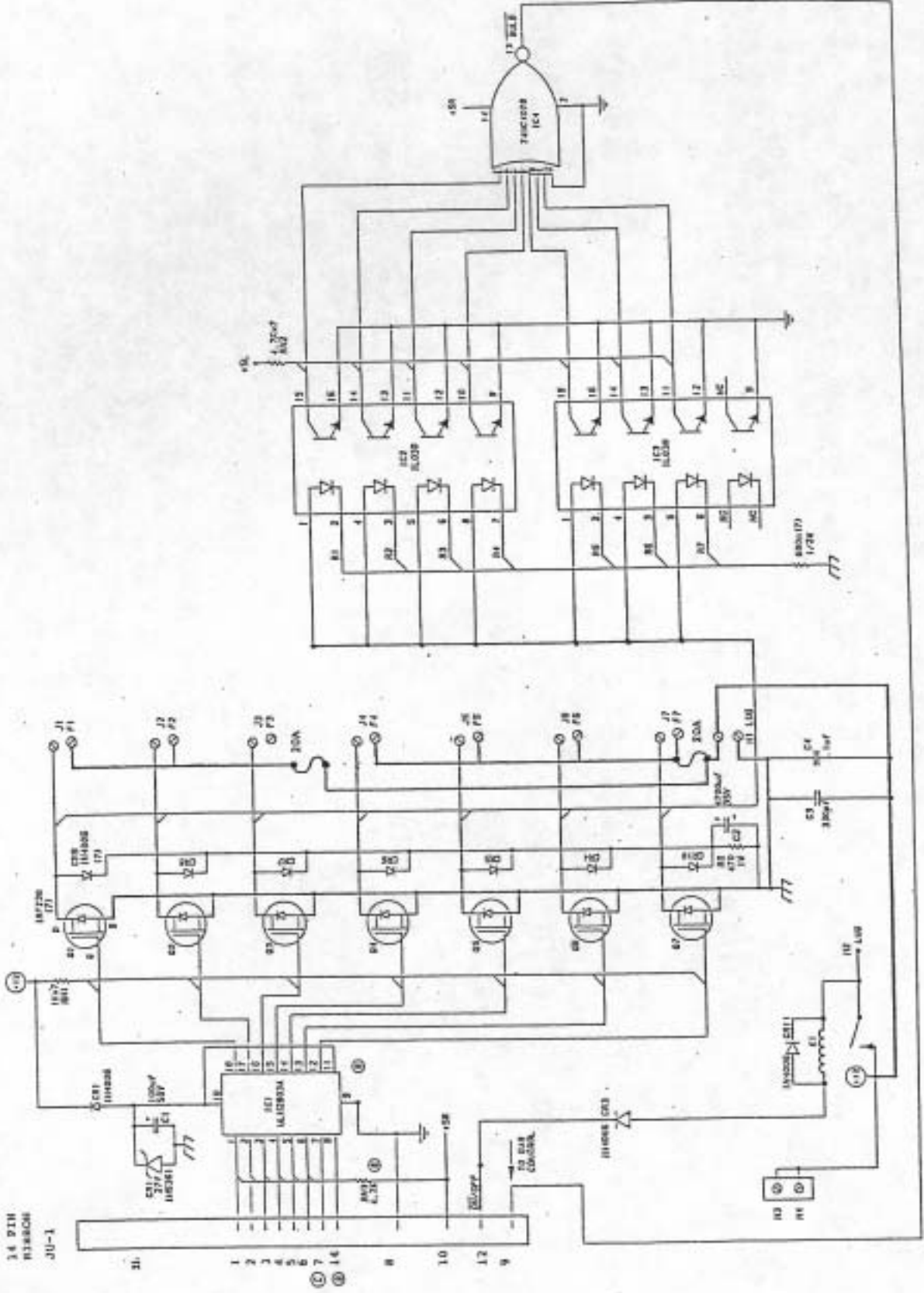

J1-78 CONNECTOR COMES FROM BRK CONTROLLER PCB

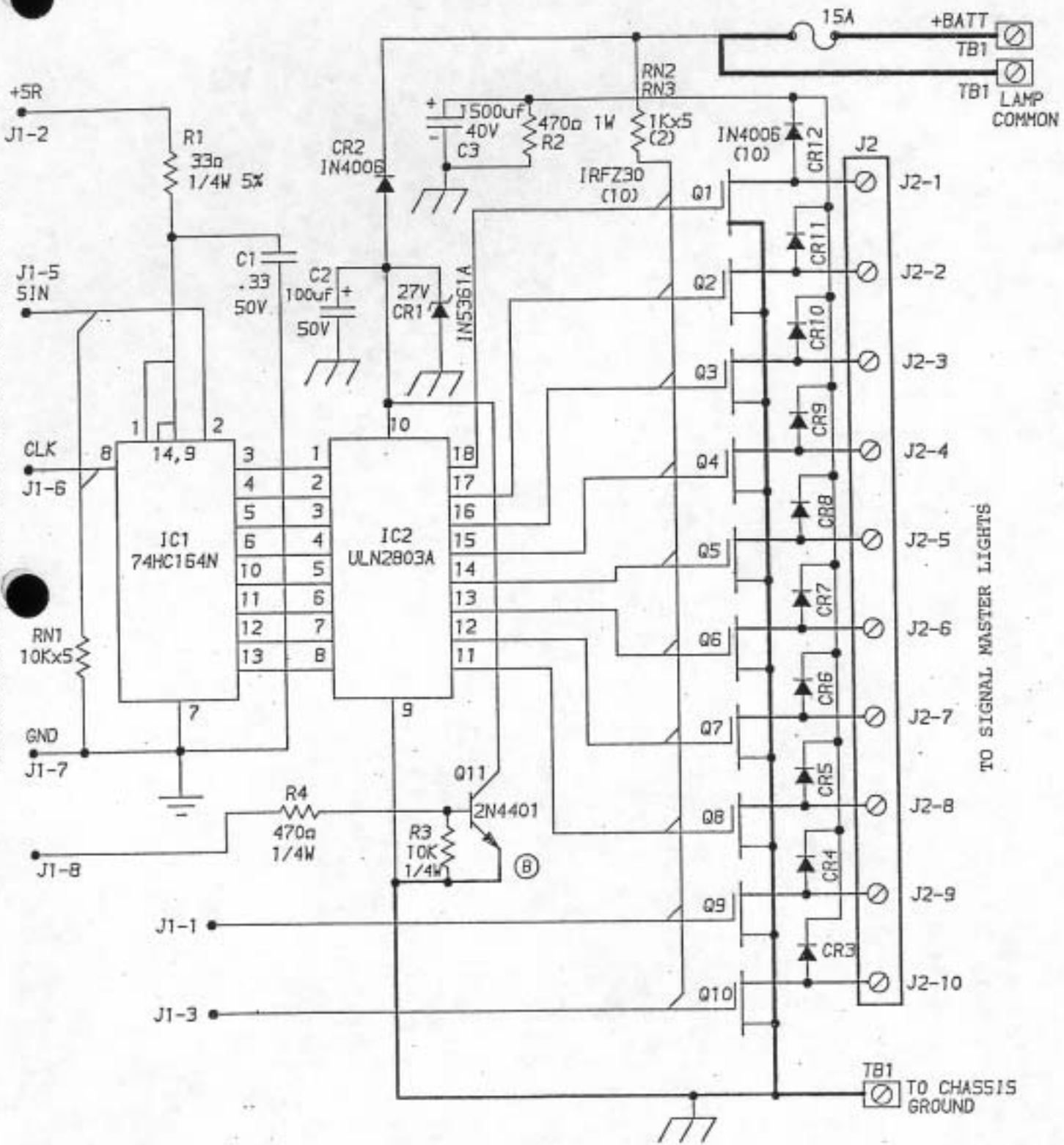

SIGNAL MASTER PC BOARD

PIN #	FUNCTION	WIRE COLOR
1	ON/OFF	BLACK
2	RECEIVE	BROWN
3	HR SIGNAL	RED
4	SPARE/XMIT	ORANGE
5	SPARE	YELLOW
6	PIGTAIL 1	GREEN
7	PIGTAIL 2	BLUE
8	PIGTAIL 3	VIOLET
9	PIGTAIL 4	WHITE

INTERFACE
PC BOARD
(1 OF 2)

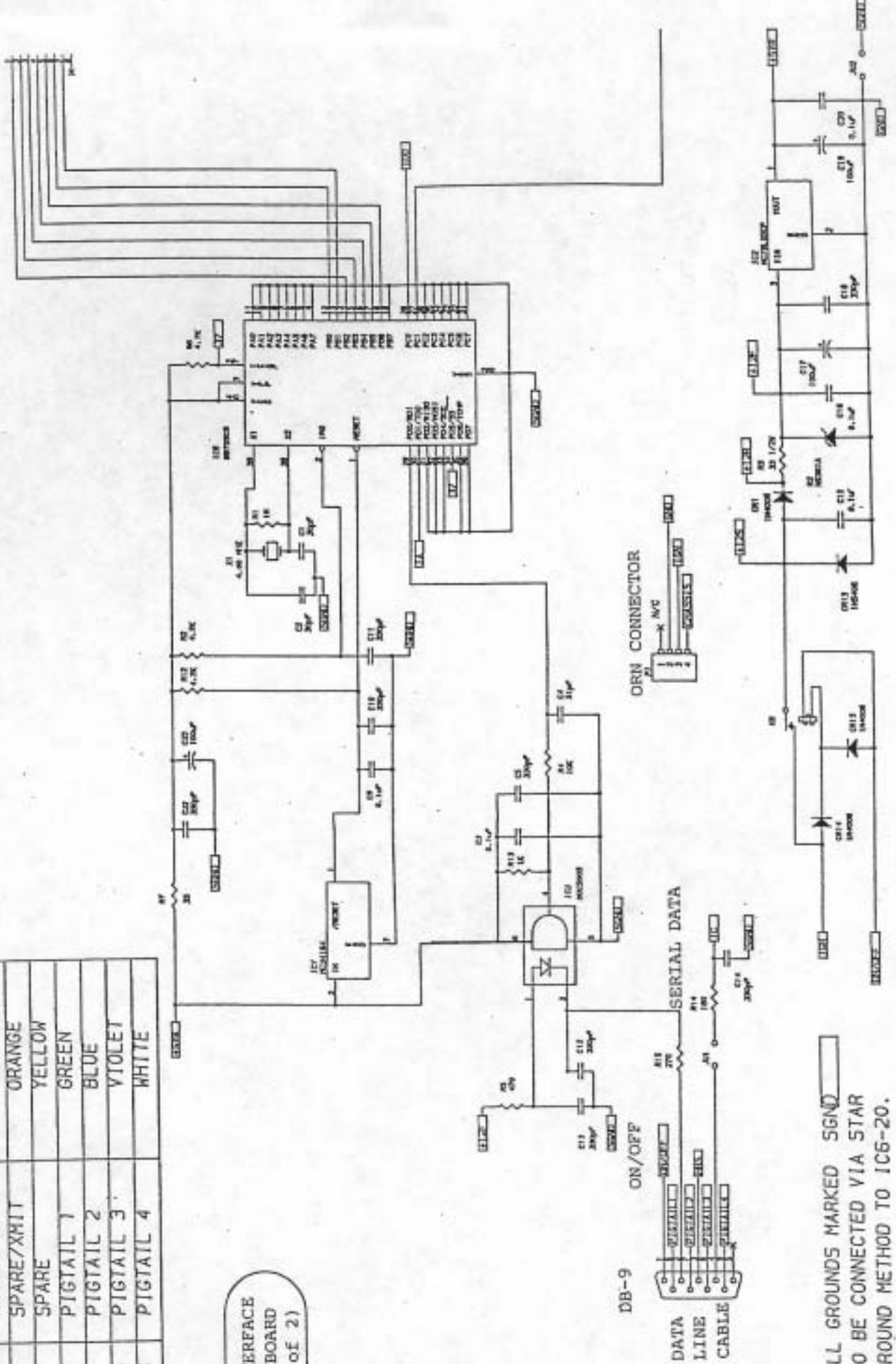

ALL GROUNDS MARKED SGND TO BE CONNECTED VIA STAR GROUND METHOD TO IC6-20.



HORN INPUT
GROUND
TRUNK RELEASE
SHOT GUN
CLEAR SPOT
WIG WAG

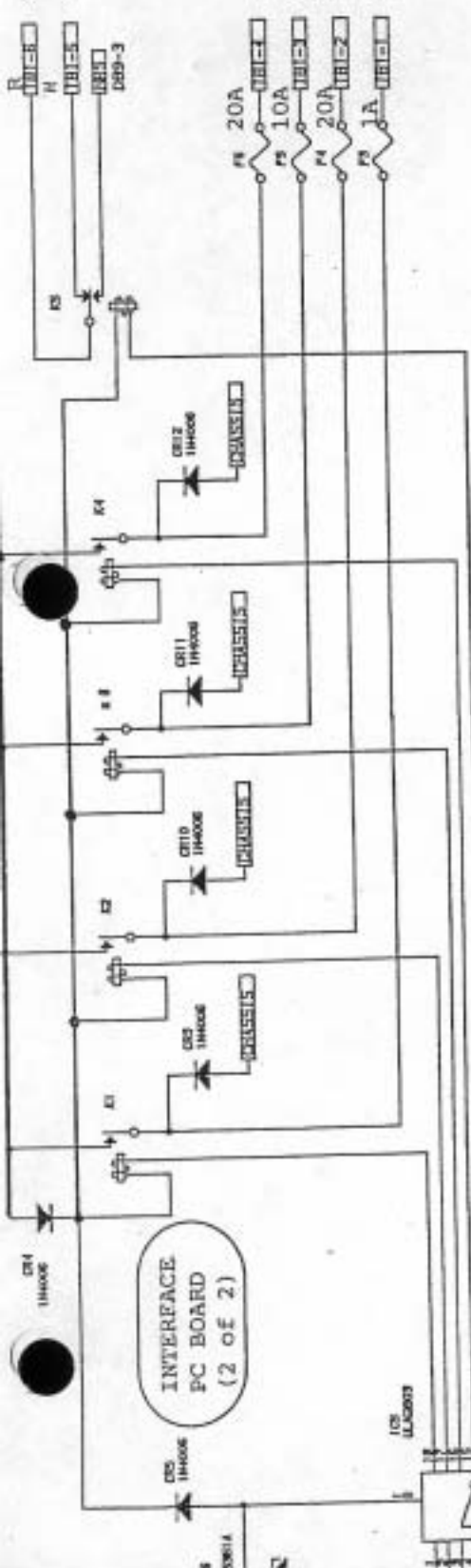

PIGTAILS



FOR EXTRA PARALLEL OUTPUTS

J2	FUNCTION	WIRE COLOR
1	PIGTAIL B+	RED
2	PIGTAIL #1	WHITE
3	PIGTAIL #2	ORANGE
4	PIGTAIL #3	GREEN
5	PIGTAIL #4	BROWN
6	PIGTAIL GND	BLACK

